

# Installation Manual

## Industrial Booths

Class I

- >> Open Front Booths - IB
- >> Open Front Bench Booths - IBB
- >> Enclosed Industrial Booths - EIB
- >> Industrial Exhaust Chamber - IBC
- >> Exhaust Bench - EB

This Installation Manual reviews an introduction, safety, component description, installation, maintenance and warranties of RTT's industrial spray booths.

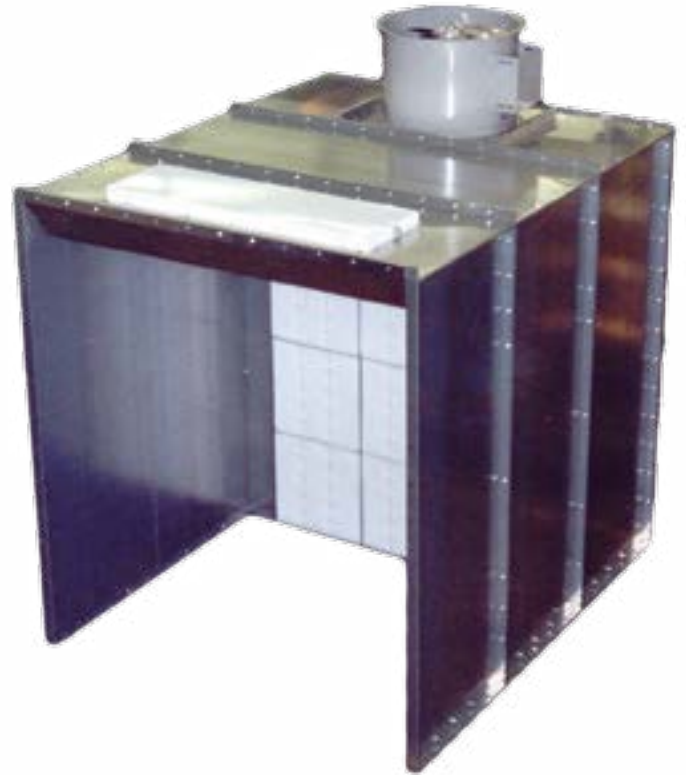

**888-452-6684**  
**[www.rtt solutions.com](http://www.rtt solutions.com)**

Revised August 2020

# Contents

<b>1. Introduction.....</b>	<b>2</b>		
1.1 Introduction .....	2		
1.2 Receiving, Unpacking, and Reporting Missing Items.....	2		
<b>2. Safety .....</b>	<b>4</b>		
2.1 Safety Alert Symbol and Signal Words.....	4		
2.1.1 Assembly Hazards.....	5		
2.1.2 Operational Hazards .....	6		
2.1.3 Maintenance Hazards.....	7		
2.1.4 Fire Hazard .....	7		
2.2 Safety Decals.....	8		
2.3 NFPA 33 .....	9		
<b>3. Component Description .....</b>	<b>12</b>		
3.1 Compliance To Applicable Codes.....	12		
3.2 Material Specifications.....	12		
3.3 General Description .....	12		
3.3.1 Paint Area .....	12		
3.3.2 Exhaust Fan and Chambers .....	12		
3.3.3 Product Doors .....	12		
3.3.4 Door Latch.....	12		
3.3.5 Door Limit Switch .....	13		
3.3.6 Air Makeup Unit (Optional) .....	13		
3.4 Exhaust Filter Manometer.....	13		
3.5 Air Solenoid Valve .....	13		
3.6 Control Panel .....	13		
<b>4. Installation .....</b>	<b>14</b>		
4.1 General.....	14		
4.2 Preliminary .....	14		
4.2.1 Recommended Booth Layout Tools .....	14		
4.2.2 Booth Layout Steps .....	15		
4.2.3 Recommended Booth Installation Tools .....	16		
4.3 Planning Ahead .....	16		
4.4 Booth Assembly .....	17		
4.5 Lights .....	19		
4.6 Manometer .....	20		
4.7 Exhaust Filter Installation .....	23		
4.8 Intake Filter Installation .....	23		
4.9 Motor Installation .....	24		
4.9.1 Mounting .....	24		
4.9.2 Install Sheaves and Fan Belts .....	24		
4.9.3 Electrical .....	25		
4.10 Tubeaxial Fan.....	26		
4.11 Exhaust Duct Installation.....	26		
4.12 Product Door .....	27		
4.13 Access Door Limit Switch Installation.....	28		
4.14 Access Door Latch Installation .....	29		
4.15 Product Door Limit Switch Installation .....	30		
4.16 Checklist .....	31		
<b>5. Maintenance .....</b>	<b>32</b>		
5.1 Maintenance Interval Cart .....	32		
5.2 Daily .....	33		
5.2.1 Inspect Filters.....	33		
5.2.2 Filter Maintenance .....	33		
5.2.3 Determine Filter Condition .....	33		
5.3 Every Two Months.....	33		
5.3.1 Lubricate Door Latches.....	33		
5.4 Every Six Months .....	34		
5.4.1 Check Fan Belts .....	34		
5.5 Every Year.....	34		
5.5.1 Inspect Motor.....	34		
5.5.2 Inspect Fan Wheel.....	34		
5.5.3 Inspect and Clean Air Solenoid Valve .....	35		
<b>6. Warranty.....</b>	<b>36</b>		
6.1 Returning Items for Credit .....	36		
6.2 Back Charges For Material And Labor .....	37		

## Introduction

### **1.1 Introduction**

Thank you for purchasing a RTT spray booth. Please read and understand this manual before using your booth and follow all of the safety instructions. Please be sure to keep this manual with your booth at all times. This manual explains the assembly and routine maintenance of the RTT spray booth and covers the following:

- >> Open Front Booths - IB
- >> Open Front Bench Booths - IBB
- >> Enclosed Industrial Booths - EIB
- >> Industrial Exhaust Chambers - IBC
- >> Exhaust Bench - EB

The spray booth itself consists of four major components: paint area, exhaust fan and chamber, product doors and, in some cases, an air makeup unit. A brief description is provided for these and other related items.

The text contained in this manual is for current production models. Some instructions and maintenance procedures may not apply to your specific unit.

Equipment modifications from original design and specifications are strictly prohibited. Modifications may compromise safe operation of the booth, subjecting users to serious injury or death and may void any remaining warranty.

This Operator's Manual does not replace, nor does its use release, the operator from observing all safety or operating limitations as well as any applicable federal, state, provincial or local regulations.

### **1.2 Receiving, Unpacking, And Reporting Missing Items**

Check for damage when receiving and unloading equipment. Note on Bill of Lading "FREIGHT DAMAGE." Notify the RTT customer service department immediately of any damage.

Unpack all items and verify on packing list within ten (10) days of receipt. Notify RTT customer service department of missing items and discrepancies immediately. RTT will not pay for overnight freight on shorted items. If overnight freight is necessary, the buyer shall be accountable for freight costs.

For quality control, RTT's Shipping Department photographs all items as they are packed.

Per company policy, two independent checks are performed to verify each item against the packing list. If RTT determines that the reported shortage was checked off in our records, replacement parts will be shipped AND invoiced accordingly.

Items that can be shipped UPS usually take one to three days to receive, depending on distance. Items too large for UPS will ship via common freight. This shipping method typically takes from one to five days to reach the destination.

During the warranty period, RTT will repair or replace, free of charge, any parts that RTT has verified to be defective in materials or workmanship. If inspection of the equipment does not disclose any defect in workmanship of material, repairs will be made at a reasonable charge, which will include the costs of labor, materials and transportation.

## 2. Safety

### **2.1 Safety Alert Symbol And Signal Words**

Before assembling, operating or servicing the spray booth, you must read, understand and follow the instructions and safety warnings in this manual. Your spray booth may not be equipped with some of the optional equipment described in this manual.

#### **NEVER ALLOW ANYONE TO OPERATE THIS EQUIPMENT WITHOUT PROPER TRAINING!**

The safety information in this manual is denoted by the safety alert symbol: 

The level of risk is indicated by the following signal words:

<b> DANGER</b>
<b>DANGER - Indicates a hazardous situation, which, if not avoided, WILL result in death or serious injury.</b>

<b> WARNING</b>
<b>WARNING - Indicates a hazardous situation, which, if not avoided, could result in death or serious injury.</b>

<b> CAUTION</b>
<b>CAUTION - Indicates a hazardous situation, which, if not avoided, could result in minor or moderate injury.</b>

<b>NOTICE</b>
<b>NOTICE - Indicates a situation that could result in damage to the equipment or other property.</b>

### 2.1.1 Assembly Hazards

**⚠ WARNING**

**Prevent serious injury or death.**

**Overriding a safety system may result in unsafe equipment, which may result in serious injury or death.**

**Do not override safety devices.**

**⚠ WARNING**

**Blade hazard. Keep hands clear of rotating parts.**

**Follow lockout procedure before servicing.**

**⚠ WARNING**

**Prevent serious injury or death.**

**Use adequate lifting devices to raise, move and install booth components.**

**⚠ WARNING**

**Prevent serious injury or death.**

**Electrical installations must be performed by qualified electricians.**

**Installation must conform to all national, local, and provincial codes and standards.**

### 2.1.2 Operational Hazards

**⚠ WARNING**

Prevent serious injury or death.

Do not operate machine with guards and/or covers open or removed.

**⚠ WARNING**

Prevent serious injury or death.

Only trained and qualified personnel may operate booth.

**⚠ WARNING**

Prevent serious injury or death.

Never operate spray booth while under the influence of drugs, alcohol or while feeling ill.

**⚠ WARNING**

Prevent serious injury or death.

Always wear personal protective equipment (PPE) appropriate for job.

Read Material Safety Data Sheet for products used in spray booth.

**⚠ WARNING**

Shock hazard.

Only a qualified electrician may open electrical control cabinet.

Disconnect and lockout / tagout all power sources before adjusting, repairing, or cleaning booth.

### 2.1.3 Maintenance Hazards

#### **WARNING**

**Prevent serious injury or death.**

**Disconnect and lockout / tagout all power sources before adjusting, repairing, or cleaning booth.**

#### **WARNING**

**Prevent serious injury or death.**

**Service, maintenance and adjustments must be performed by trained and qualified personnel.**

#### **WARNING**

**Burn hazard. Do not touch hot parts.**

**Allow to cool before servicing.**

#### **WARNING**

**Prevent serious injury or death.**

**Always wear personal protective equipment (PPE) appropriate for job.**

**Read Material Safety Data Sheet for products used in spray booth.**

### 2.1.4 Fire Hazard

No smoking or open flame in or near spray booth. Local fire codes prohibit smoking in the vicinity of spray painting operations.

#### **WARNING**

**Explosion and fire hazard.**

**No smoking or open flame within 50 feet of spray booth.**

Do not store flammable liquids adjacent to or inside spray booth. Read all product labels and instructions.

Do not use any electric powered airless spray rigs, pressure washers or similar equipment when applying a low flash point solvent or peel coating. Run spray booth exhaust fan to purge dangerous vapors that could ignite or explode while cleaning or performing maintenance inside spray booth.

**AN APPROVED FIRE PROTECTION SYSTEM MUST BE INSTALLED ON YOUR SPRAY BOOTH TO COMPLY WITH NFPA 33, SECTION 9. PORTABLE FIRE EXTINGUISHERS MUST BE LOCATED IN OR AROUND YOUR PAINT MIX ROOM PER NFPA 10.**

## 2.2 Safety Decals



**⚠ DANGER**

**Electrical Shock Hazard**

Disconnect electric before service.

More than one disconnect switch may be required to disconnect electric from equipment.

Equipment must be properly grounded.

Failure to follow these instructions can result in death or electrical shock.

Printed in the USA

---

**⚠ DANGER**

**Risque de Choc Electrique**

Débrancher le courant avant l'entretien.

Plus qu'un interrupteur de verrouillage peut être requis pour débrancher le courant électrique de cet appareil.

L'appareil doit être connecté à une source de courant reliée à la terre.

Le non-respect de ces instructions peut entraîner de la mort ou des chocs électriques.

Imprimé aux E.-U.

**⚠ DANGER**

**Severe Injury Hazard**

Do not enter equipment while in operation.

Equipment may start automatically.

Do not operate with door open.

Installation, operation and service must be done by a trained technician only.

Failure to follow these instructions can result in death or injury.

Printed in the USA

---

**⚠ DANGER**

**Risque de Blessures Graves**

Ne pas entrer dans cet appareil pendant l'opération.

Cet appareil peut démarrer automatiquement à tout moment.

Ne pas opérer l'appareil avec la porte ouverte.

L'installation, l'opération et l'entretien doit être effectués par un installateur éprouvé.

Le non-respect de ces instructions peut entraîner de la mort ou des blessures.

Printed in the USA

**⚠ WARNING**

Improper installation, adjustment, alteration, service or maintenance can result in death, injury or property damage. Read the Installation, Operation and Service Manual thoroughly before installing or servicing this equipment.

*Installation, modification, réglage ou maintenance incorrectes peuvent provoquer de la mort, des blessures ou des dégâts matériels. Lisez attentivement le manuel d'installation, d'opérations et d'entretien avant l'installation ou l'entretien de cet équipement.*

---

This heater must be installed in accordance with the manufacturer's instructions and local codes. In the absence of local codes, follow the National Fuel Gas Code, ANSI Z223.1 / NFPA 54 of the CAN/CSAB149 installation code.

Cet aérotherme doit être installé en accord avec les instructions du fabricant et les réglementations locales. S'il n'y a pas des réglementations locales, l'installation doit être en accord avec le Code National de Gaz de Carburant, ANSI Z223.1 / NFPA 54 ou le Code d'installation, CAN/CSA-B149.

PN 01010431 Rev A

**⚠ WARNING**

**To protect you and others against death or serious injury, all applicable labels shown must be on the booth and must be legible.**

**If any of these labels are missing or cannot be read, contact your RTT for replacement labels.**

## **2.3 NFPA 33 Standards for Spray Application**

Reprinted with permission from NFPA 33-2016, Standard for Spray Application Using Flammable or Combustible Materials, Copyright © 2010, National Fire Protection Association, Quincy, MA. This reprinted material is not the complete and official position of the NFPA on the referenced subject, which is represented only by the standard in its entirety. The following is section 10 from NFPA 33:

**10.1** General. Maintenance procedures shall be established to ensure that all spray application apparatus and processes are operated and maintained in accordance with the manufacturers specifications and the requirements of this standard. Maintenance shall be the responsibility of the users of the apparatus and processes.

**10.1.1** Spray application operations shall not be conducted outside predetermined spray areas.

**10.1.2** Inspection of extinguishing systems shall be conducted to ensure that the performance of the extinguishing system components will not be affected by overspray and residues.

**10.2** Combustible Deposits.

**10.2.1** All spray areas shall be kept free of excessive accumulation of deposits of combustible residues.

**10.2.2** Combustible coverings (thin paper, plastic) and strippable coatings shall be permitted to be used to facilitate cleaning operations in spray areas.

**10.2.2.1** Where plastic covering is used, it shall be of a static dissipative nature or shall have a maximum breakdown voltage of 4 kV to prevent accumulation of a hazardous static electric charge.

**10.2.3** If residue accumulates to excess in booths, duct or duct discharge points, or other spray areas, all spraying operations shall be discontinued until conditions have been corrected.

**10.3** High-Pressure Hose Lines. High-pressure hose lines that convey flammable or combustible coating material in “airless” spray application operations shall be inspected daily and shall be repaired or replaced as necessary. Hose lines and equipment shall be located so that, in the event of a leak or rupture, coating material will not be discharged into any space having a source of ignition.

**10.4** Maintenance Procedures

**10.4.1** Overspray collectors shall be inspected daily and clogged filters shall be discarded and replaced. Maintenance procedures shall be established to ensure that overspray collector filters are replaced before restriction to airflow is reduced below the minimum established by Section 7.2.

**10.4.2** At the close of the day’s operation, all discarded overspray collector filters, residue scrapings, and debris contaminated with residue shall be removed immediately to a designated storage location, placed in a noncombustible container with a tight-fitting lid, or placed in a water-filled metal container.

**10.5** Waste Containers.

**10.5.1** Approved waste containers shall be provided wherever rags or waste are impregnated with sprayed material, and all such rags or waste shall be deposited therein immediately after use. The contents of waste containers shall be placed in a designated storage location.

RTT Waste containers containing flammable liquids shall be located in ventilated areas that meet the requirements of Chapter 7. Such areas shall also meet the electrical area classification requirements of 6.5.5.

**10.5.3** Waste containers for flammable liquids shall be constructed of conductive materials and shall be bonded and grounded.

**10.5.4** Waste containers for flammable liquids shall be handled and stored in accordance with Chapter 8.

**10.6** Clothing. Employees' clothing contaminated with sprayed material shall not be left on the premises overnight unless kept in metal lockers.

**10.7** Cleaning Operations.

**10.7.1** Scope. This section shall apply to the use of flammable or combustible liquids for the flushing and cleaning of equipment.

**10.7.2** Liquids. Class I and Class II liquids used in cleaning operations shall be in original shipping containers or in listed safety containers.

**10.7.3** Location. Cleaning operations using flammable or combustible liquids shall be conducted inside a spray area with ventilating equipment operating or in ventilated areas that meet the requirements of Chapter 7. Such areas shall also meet the electrical area classification requirements of 6.5.5.

**10.7.4** Equipment. Equipment using flammable or combustible liquids shall meet the requirements of 6.5.5 and shall be bonded and grounded.

**10.7.5** Manual Cleaning. Individual manual cleaning operations shall be limited to not more than 4 L (1 gal) of flammable or combustible liquid for each cleaning operator.

**10.7.6** Liquid Storage. Flammable and combustible liquids shall be handled and stored in accordance with Chapter 8. Containers used for handling, storage, or recovery of Class I liquids shall be constructed of conductive materials and shall be bonded and grounded.

**10.8** Solvent Distillation Units (Solvent Recyclers).

**10.8.1** Scope.

**10.8.1.1** Section 10.8 shall apply to solvent distillation units having distillation chambers or still pots that do not exceed 227 L (60 gal) capacity and are used to recycle Class I, Class II, and Class IIIA liquids. [30:19.6.1.1]

**10.8.1.2** This section shall not apply to research, testing, or experimental processes; to distillation processes carried out in petroleum refineries, chemical plants, or distilleries; or to distillation equipment used in dry cleaning operations. [30:19.6.1.2]

**10.8.2** Equipment. Solvent distillation units shall be approved or shall be listed in accordance with ANSI/UL 2208, Standard for Solvent Distillation Units. [30:19.6.3]

**10.8.3** Solvents. Solvent distillation units shall only be used to distill liquids for which they have been investigated and that are listed on the unit's marking or contained within the manufacturer's literature. [30:19.6.3]

**10.8.3.1** Unstable or reactive liquids or material shall not be processed unless they have been specifically listed on the systems markings or contained within the manufacturer's literature. [30:19.6.3.1]

#### **10.8.4** Location [30:19.6.4]

**10.8.4.1** Solvent distillation units shall only be used in locations in accordance with their approval or listing.

**10.8.4.2** Solvent distillation units shall not be used in basements.

**10.8.4.3** Solvent distillation units shall be located away from potential sources of ignition, as indicated on the unit's marking.

**10.8.5** Liquid Storage. Distilled liquids and liquids awaiting distillation shall be stored in accordance with Chapter 6 of NFPA 30.

**10.9** Spontaneous Ignition Hazards. The same spray booth shall not be alternately used for different types of coating materials if the combination of the materials is conducive to spontaneous ignition, unless all deposits of the first-used coating material are removed from the booth and exhaust ducts prior to spraying with the second coating material.

**10.10** Chlorinated Solvents. Coating materials containing chlorinated solvents shall not be used with spray application apparatus or fluid-handling equipment if the chlorinated solvent will come into contact with aluminum within a piping system, pump, enclosed container, or any enclosure that is capable of being pressurized by the potential reaction. This shall apply even if the container or system has been constructed with pressure relief devices.

**10.11** Smoking. Signs stating NO SMOKING OR OPEN FLAMES in large letters on contrasting color background shall be conspicuously posted at all spray areas and paint storage rooms.

**10.12** Hot Work. Welding, cutting, and other spark producing operations shall not be permitted in or adjacent to spray areas until a written permit authorizing such work has been issued. The permit shall be issued by a person in authority following his or her inspection of the area to ensure that precautions have been taken and will be followed until the job is completed.

## 3. Component Description

### **3.1 Compliance To Applicable Codes**

This spray booth is designed to be in strict accordance with the National Fire Protection Association Standard Number 33, “Spray Application Using Flammable Combustible Materials. The NFPA Standard Safety Code for the Design, Construction and Ventilation of Spray Finishing Operations.” This spray booth meets or exceeds the requirements of the Occupational Safety and Health Administration (OSHA).

### **3.2 Material Specifications**

The spray booth panels, filter racks and product doors are constructed of 18-gauge steel, conforming to ASTM A653 “Lock Forming Quality”. All structural steel channel and angle conform to ASTM A36.

### **3.3 General Description**

The spray booth consists of four major components: paint area, exhaust fan and chamber, product doors and, in some cases, an air makeup unit. A brief description is provided for these and other related items.

#### **3.3.1 Paint Area**

The paint area is the actual “booth” part of the spray booth. Parts are placed in this area, through product doors, if so equipped, to be painted. Air flows from the intake filters of the booth to the exhaust filters. The booth is constructed of 18-gauge galvanized sheet metal panels which are bolted together. The booth exhaust is routed through the exhaust plenum at the exit of the booth. The exhaust fan then routes the exhaust out through the exhaust duct and discharges it at a point above the roof height of the building.

#### **3.3.2 Exhaust Fan And Chambers**

The booth exhaust chamber(s) is/are located as shown in the mechanical drawing package included with this manual. Gases are exhausted through the exhaust duct by an electrically powered fan. The fan is made of spark resistant material and the motor is located out of the air stream. The exhaust chamber(s) operate(s) under a negative pressure to induce the required airflow through the exhaust filters.

#### **3.3.3 Product Doors**

The product doors can be filtered or solid and may be either overhead doors, bi-fold doors, or tri-fold doors. Some industrial spray booths have an open front in lieu of product doors. Overhead doors are equipped with an intrinsically safe pneumatic safety edge. There are two 3-button controls to operate each door. Doors may also be manually operated.

#### **3.3.4 Door Latch**

Door latches secure doors in closed position and hold contact against rubber seal. Latches are pressure relief latches that allow doors to open in case of explosion. This feature also allows for ease of booth operator egress from the spray booth by applying moderate pressure to the door from inside the booth.

### **3.3.5 Door Limit Switch**

Optional limit switch to indicate when a door is open on the booth. If a door is in the open position, micro switch contact is opened which breaks the circuit for the paint air solenoid.

### **3.3.6 Air Makeup Unit (Optional)**

The air makeup unit (AMU) supplies filtered, heated atmospheric air. This unit may be heated by natural gas, LP gas, steam coils or hot water coils. The temperature of the AMU discharge air is controlled by a temperature controller. The airflow capacity of the fan and motor are matched to the airflow capacity of the spray booth exhaust fans. Some air makeup units also have the capability to provide a paint cure cycle. This cycle, employed after the paint spraying operations are complete, typically involves supplying air that is heated to the paint area of the booth to decrease paint cure times.

### **3.4 Exhaust Filter Manometer**

Manometer is used to measure pressure drop across exhaust filters to indicate the condition of the filters.

### **3.5 Air Solenoid Valve**

The function of this valve is to interrupt supply of compressed air to painting equipment under certain conditions. This is done to prevent painting from occurring when the booth is not operating as designed or if any booth doors are open. The air solenoid valve is electrically interlocked with booth intake and exhaust fans. If optional switches are purchased, it is also interlocked with product doors and personnel doors. If a fan is not operating properly, or if a door is open, the air solenoid valve will shut off flow of pressurized air to spray gun.

Unit should be installed downstream of any regulators and filters and upstream of painting equipment. It should be located near fitting to which painting equipment connects in order to ensure rapid loss of supply pressure.

### **3.6 Control Panel**

The spray booth may be equipped with an optional electrical control panel. Electrical schematics are located inside the control panel. Also shown on this drawing is the wiring required for installation. No spare parts are provided with control panel. Panel and its associated wiring must be installed by a licensed electrician. The cabinet that houses controls is either NEMA 1 or NEMA 12 rated. It is not suitable for installation in a Class I, Division II area. Refer to Chapter 6 in the NFPA 33 Standard and consult with the local authority having jurisdiction for definition of this area for paint spray booth.

## 4. Installation

### 4.1 General

This manual is a guide for installing a variety of spray booths. The assembly drawings enclosed are specific for the booth you have purchased. This drawing is an exploded isometric drawing showing the relationship of each panel or part to the next one. A packing list of all components is provided and must be used in addition to the drawing to identify all components.

All DAMAGES MUST be reported within 24 hours of receipt and a freight claim filed with the carrier.

### 4.2 Preliminary

RTT booths are manufactured in accordance with NFPA 33 standard for spray application using flammable or combustible materials. However, local codes and regulations may apply to the installation and use of this product. All permits and approvals should be obtained prior to installation and use of the spray booth.

1. Uncrate and inventory all spray booth components to ensure all of the parts are accounted for. Each component is numbered on the exploded view.
2. The floor surface of the booth must be non-combustible material of such character as to facilitate the safe cleaning and removal of residues. The floor surface must be flat and level.
3. Mark the dimensional outline of booth on floor.
4. Follow the step-by-step instructions provided.

#### 4.2.1 Recommended Booth Layout Tools

- >> Chalk line or self-leveling 5-way laser
- >> Tape measure
- >> Marker
- >> Framing square

Use the 3-4-5 method (Pythagorean Theorem)  $A^2 + B^2 = C^2$  for a right triangle to layout and square the booth. C is the longest side (hypotenuse) and A and B are the two shorter legs. If a triangle has sides measuring 3, 4 and 5 feet (or any other unit), it must be a right triangle with a 90° angle between the short sides. You can multiply each number by the same amount and still use this method. For example let's say that the booth width being installed is 9' I.D., use a multiplier of 3 to achieve the 9' I.D. working width of the booth for your first line ( $A^2$ ) and the right triangle will consist of the following dimensions:

- >>  $3 \times 3 = 9$  (first line  $A^2$ )
- >>  $4 \times 3 = 12$  (second line  $B^2$ )
- >>  $5 \times 3 = 15$  (third line  $C^2$ ) Step one:

Locate a building drawing showing the booth in the building.

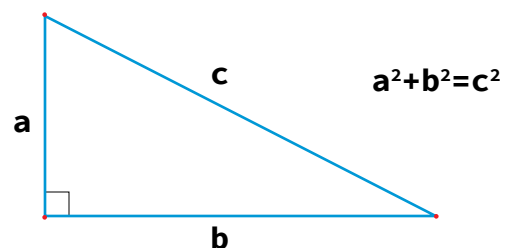

#### 4.2.2 Booth Layout Steps

##### Step 1:

Locate a building drawing showing the booth in the building.

##### Step 2:

Locate a dimension shown from a reference point such as outside wall, pit, conveyor, building structure, other equipment, etc. to the inside dimension of spray booth.

##### Step 3:

Using a chalk line, mark that dimension at two points along a wall (reference point example) and snap a line on the floor.

##### Step 4:

Locate the back of the booth and make a mark on the first line that was snapped for the first corner of the booth (I.D.), using 9' as the first line dimension (A<sup>2</sup> example) make another mark at 9' for the back wall of the booth

##### Step 5:

Using 12' as our second line dimension (B<sup>2</sup> example) make another mark at 12' from one of the corner markings of the back wall off of the first line snapped. When doing so, be sure to stay as square as possible. This is when a framing square comes in handy. Once marked, snap the second line.

##### Step 6:

Using 15' as our third line dimension (C<sup>2</sup> example) mark and scribe an arc crossing the end of the second line snapped from the opposing corner marking of the back wall off of the first line snapped. This mark is now perfectly square to the back wall of the booth. Snap the third line between these two marks.

##### Step 7:

Pull two points off of the third line and snap a fourth line marking the interior work area of the booth. Now that the square interior of the booth is complete, proceed with the rest of the booth (exhaust chambers, fans, air make-up unit etc.) to verify that all components are placed as planned without obstruction.

##### Step 8:

Using a laser, verify building clearance, fan ductwork and air makeup unit (if applicable) orientation.

##### Step 9:

Using a laser, verify that the floor is level. Any area that will have more than a ¼" gap will need to be shimmed.

##### Step 10:

Double check the entire layout for accuracy and to prevent losing your layout, spray clear coat over it before beginning the booth installation.

### **4.2.3 Recommended Booth Installation Tools**

- >> Step ladders (4', 6' and 8') and multi-use ladder
- >> Wrench and socket sets (1/2", 9/16" and 3/4" most common)
- >> Screw driver set
- >> Allen wrenches
- >> Hammer and dead blow
- >> Alignment pins and pry bar
- >> Level (magnetic)
- >> Caulk gun and utility knife
- >> 1/4" and 3/8" drive cordless impacts
- >> 1/2" drive drill
- >> Drill bits and uni-bit/ step-bit
- >> Hammer drill (SDS)
- >> Metal nibblers/ cutters
- >> Cut-off saw
- >> Welding and plasma machines

### **4.3 Planning Ahead**

1. Clearances between other work areas and combustible storage areas must be held as follows:
  - >> 3 ft. minimum clearance at all sides and sealed entry ways (i.e., door ways).
  - >> 3 ft. minimum clearance at all non-sealed entry ways (i.e., the open face of spray booth or a silhouette openings).
  - >> 10 ft. minimum clearance must be held between the exhaust stack of the booth and the intake of another apparatus. NFPA 33 dictates a minimum discharge clearance of 3 ft. from the nearest combustible material; however, stack height requirements vary with individual states and can be up to 1½ times the building's roof height from grade.
2. Permits are not included. It is the responsibility of the end user to acquire all permits to install a booth.
3. A FIRE SUPPRESSION SYSTEM IS NOT INCLUDED WITH THE BOOTH BUT IT IS REQUIRED. Generally this is supplied and installed by a licensed local installer.
4. Electrical installation must be performed by a licensed electrician familiar with national, local electrical codes and regulations in your location.

#### 4.4 Booth Assembly

When assembling the booth, leave bolts finger tight until the entire booth is assembled. All flanges should face outward. Install bolts from inside so nut is outside of the booth. Use a drift pin to align panel holes when two or more panels are difficult to align by hand.

Lay out all floor channel for exhaust chamber and walls. As you attach wall panels together, they will also bolt to the floor channel.

<b>⚠ WARNING</b>
<p><b>Prevent serious injury or death.</b></p> <p><b>Most booth components weigh 50-500 lbs.</b></p> <p><b>Use adequate lifting devices to raise, move and install booth components.</b></p>

<b>NOTICE</b>
<p><b>Prevent equipment damage.</b></p> <p><b>Spray booth roof will not support a person. Do not attempt to stand or walk on spray booth roof.</b></p>

Refer to exploded view drawings included with your spray booth.

1. Starting with exhaust chamber at either rear corner, bolt one corner panel and one rear wall corner panel together (use tie channel where applicable).
2. Bolt opposite rear sidewall panel to rear wall panel.
3. Bolt all rear wall panels in place.
4. Bolt tie channel along top edge of rear wall panels.
5. Place exhaust fan panel above side and rear wall panels and bolt in place.
6. Insert filter filler panels between sidewall, roof panels and exhaust chamber. Bolt in place.
7. Following exploded view drawings, continue alternately assembling wall panels and roof panels to each other until you reach front end of booth. Finish off roof section by attaching fire curtain if needed. If booth has front doors, no fire curtain is needed.

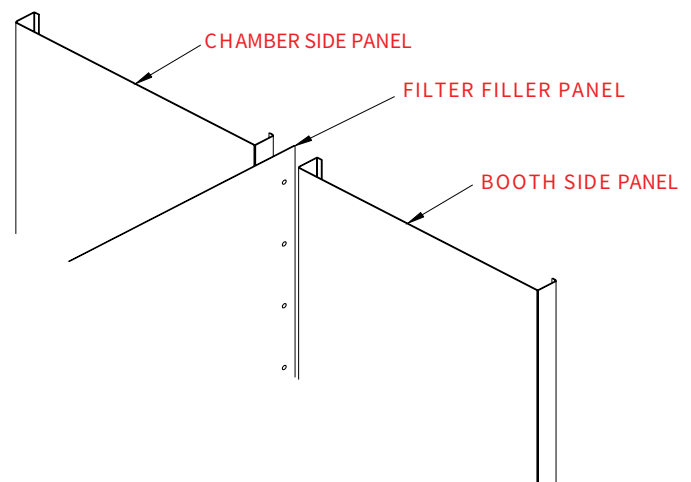

8. Verify walls are plumb and booth is square and on floor layout marks. Tighten all mounting hardware.
9. Anchor floor channel to floor at a minimum of every 12 inches.
10. Caulk all panel joints inside the booth with the caulk provided. Do not use a silicone caulk.
11. If booth is supplied with a personnel door or product doors, apply gasket to perimeter of all door openings. Attach door hardware and adjust latches. Level door with doors off, then attach doors to hinges.

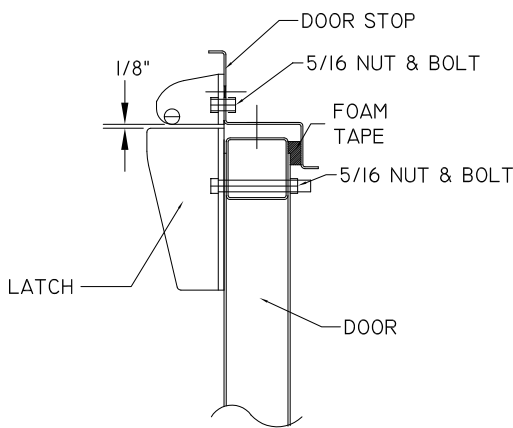

**DOOR LATCH AND SEAL DETAIL**

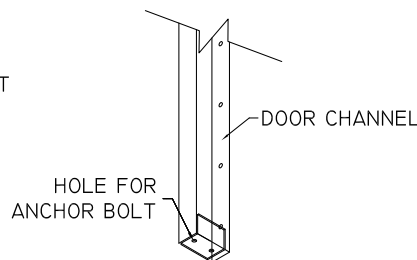

**DOOR FRAME BASE DETAIL**

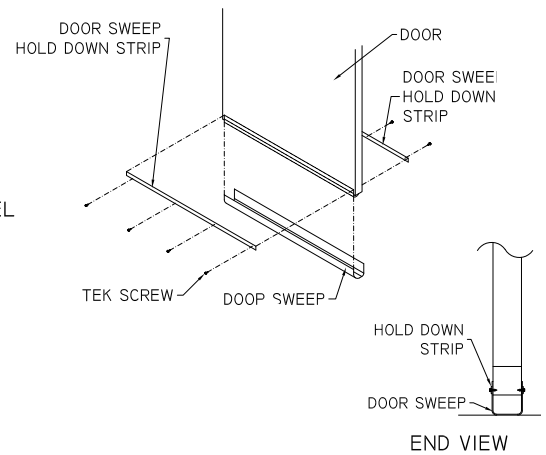

**PRODUCT DOOR DOOR SWEEP DETAIL**

12. Other installation that may apply to your type of booth

USE 3/8" Ø HARDWARE TO ASSEMBLE @ EACH 5-HOLE PATTERN (NUT & BOLT)

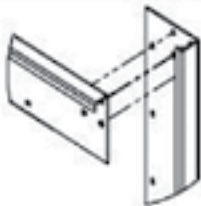

USE 1/2" Ø HARDWARE TO ASSEMBLE ITEMS PICTURED (BOLT, NUT & LOCK WASHERS)

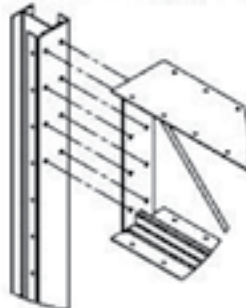

FOR OPTIMAL DOOR SEAL APPLY 3/4" GASKET TO THIS SURFACE

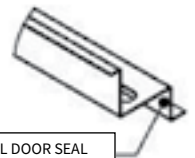

USE 1/2" Ø HARDWARE TO ASSEMBLE ITEMS PICTURED (BOLT, NUT & LOCK WASHERS)

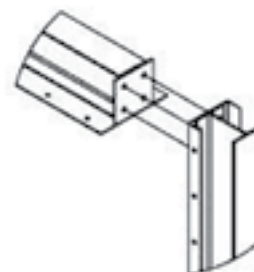

INSTALL PANEL STIFFENERS ON THE OUTSIDE OF CEILING PANEL JUNCTION AS SHOWN DO NOT INSTALL IN BETWEEN

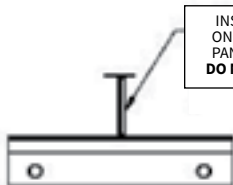

## 4.5 Lights

### **⚠ WARNING**

**Prevent serious injury or death.**

**Electrical installations must be performed by qualified electricians.**

**Installation must conform to all national, local, and provincial codes and standards.**

1. Place light fixture into booth panel, center in opening, and bolt in place.
2. Install light fixture in panel from outside of booth as shown in drawing.
3. Caulk perimeter of light fixture lens frame with appropriate caulking.
4. The fixture is provided with an interlock switch that has a normally open contact, which opens when the fixture lens is removed from fixture. The switch is to be wired to disable spray equipment used in spray booth.

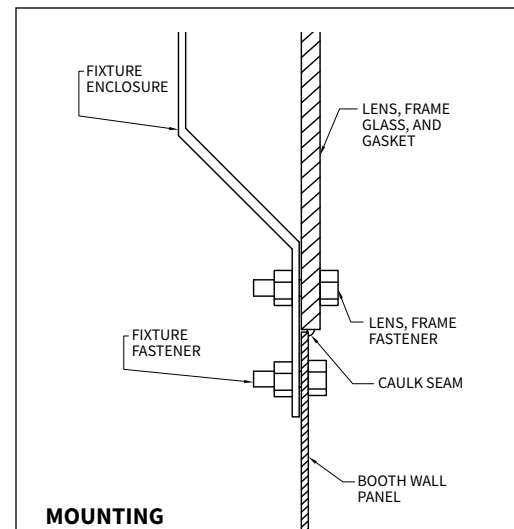
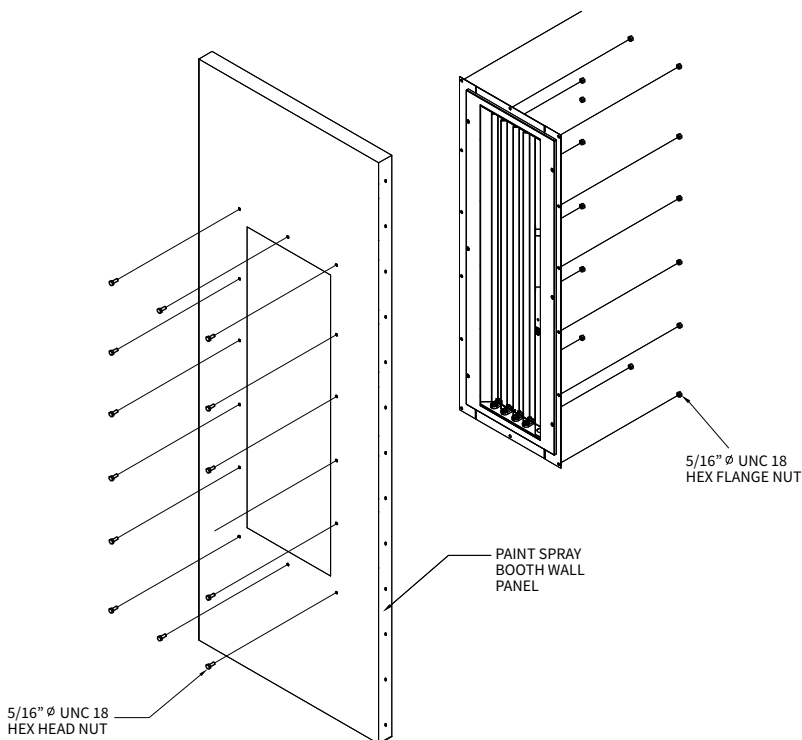

#### **MOUNTING DETAIL**

**CAUTION:**  
 WHEN TIGHTENING LENS FRAME FASTENERS, TIGHTEN USING HAND TOOLS ONLY. TIGHTEN UNTIL SIDES OF METAL LENS FRAME MAKES CONTACT WITH FIXTURE ENCLOSURE. OVER TIGHTENING WILL CAUSE LENS FRAME TO WARP AND WILL BREAK DOWN VAPOR SEAL OF LENS

#### **4.6 Manometer**

Locate manometer on the exhaust chamber so that hardware is not visible inside the booth and can easily be viewed daily.

Install close to exhaust filter wall to keep tubing length to a minimum. Excess tubing length will reduce accuracy of the manometer. The high port will connect to work chamber, and the low port will connect to chamber on the suction side of the filter grid.



1. Drill a hole in booth wall just large enough for the plastic hose barb to fit through (approx. 13/32). Install washer and nut on back side. Do not over tighten.



2. Mount manometer on booth wall and ensure it is level using bubble level on manometer. Manometer must be level or it will not be accurate.



3. Turn “Zero Set” knob counter clockwise until it stops, then turn knob counter clockwise three full turns. This will place the adjustment knob in the middle of its travel range. Remove fill plug at top of manometer and slowly fill with red fluid. You will not need the entire bottle. Stop filling as soon as you can see the red fluid enter clear tube at bottom of the manometer. Turn “Zero Set” adjustment knob to set red fluid on 0 mark. If you overfill gauge, remove excess fluid by inserting a pipe cleaner through fill port to blot up excess oil. Once the red fluid is set on zero, replace the fill cap.

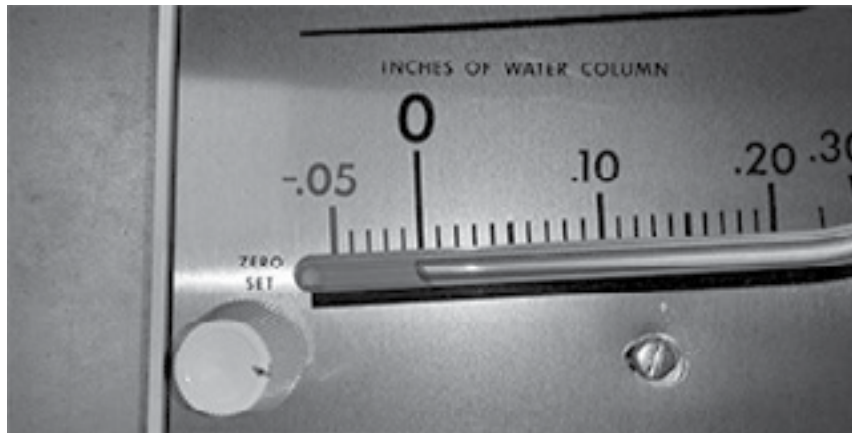
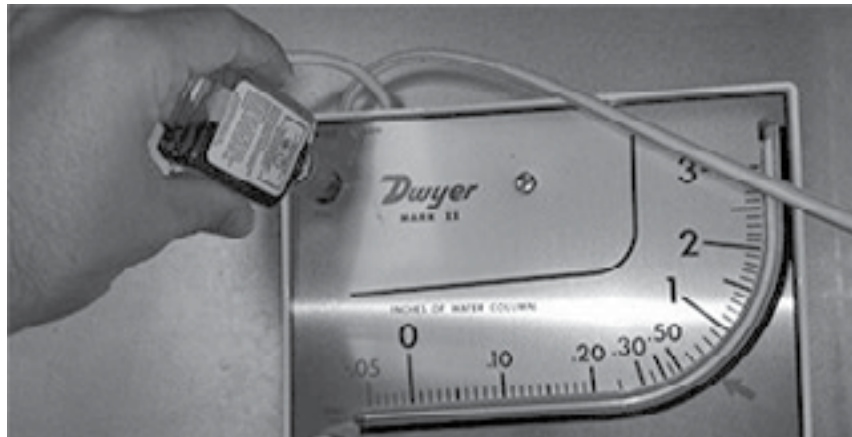

Complete booth assembly and then perform steps 4-6 to set manometer.

**IMPORTANT:** All filters in the booth must be installed and new in order to get an accurate baseline.

4. Turn on exhaust fan. If exhaust fan is connected to a VFD to control the speed of the fan, make sure it is set to run at full speed. You will notice the red fluid should move up the scale and then settle at a number. The number will be different from booth to booth, but that does not matter, this is just a baseline setting.

- Wherever the red fluid stops is where you will place the green arrow. In this example, the red fluid stopped at .25 inches of water column. So because we know our filters are rated for .5 inches of water column, and we know that with clean filters the fan is drawing .25 inches of water column, we simply add the two numbers together to tell us where the filters will pack out.

.25 inches of water + .5 inches of water = .75 inches of water total

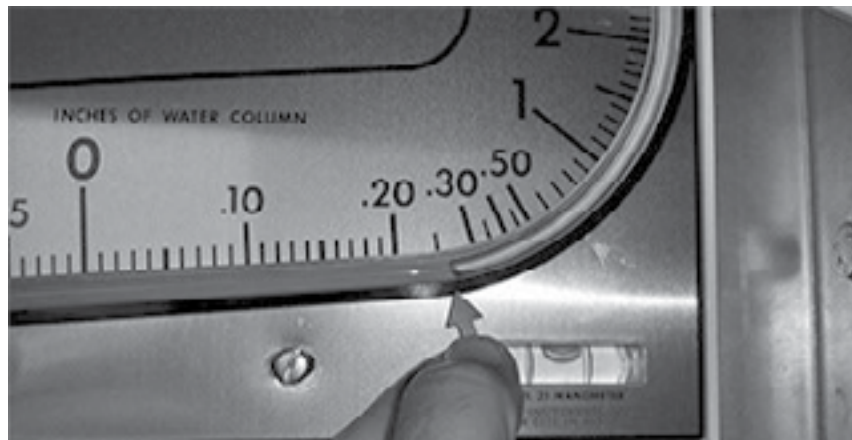

- Now that baseline is set, measure up the scale .5 inches of water. That is where you will place the red arrow.



At this point, your manometer is set up and ready to use. You should never need to move the arrows once they are placed. Always check the manometer before turning the fan on to ensure the red fluid is sitting on the 0 mark. If the fluid is not on 0, turn “Zero Set” knob to adjust fluid to zero before starting fan.

### 4.7 Exhaust Filter Installation

Install one wire grid in each filter cell with prongs facing into booth. Exhaust filters will be attached to prongs.

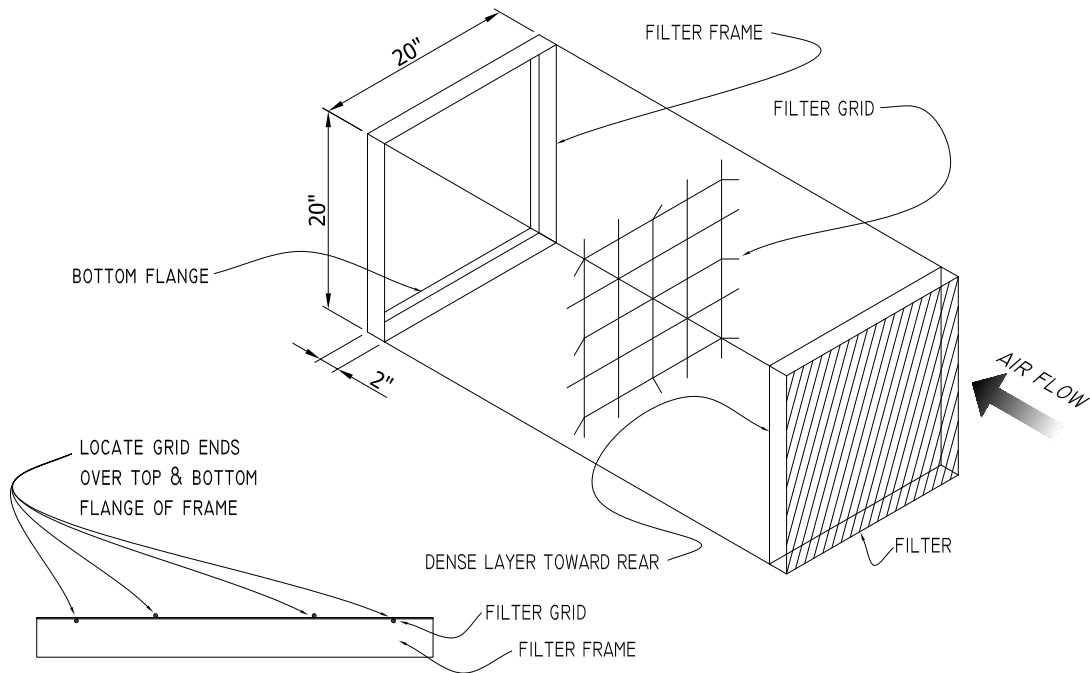

### 4.8 Intake Filter Installation

If booth has an intake plenum, insert intake filter into filter grid. The side marked "Air Leaving Side" on filter goes toward inside of booth.

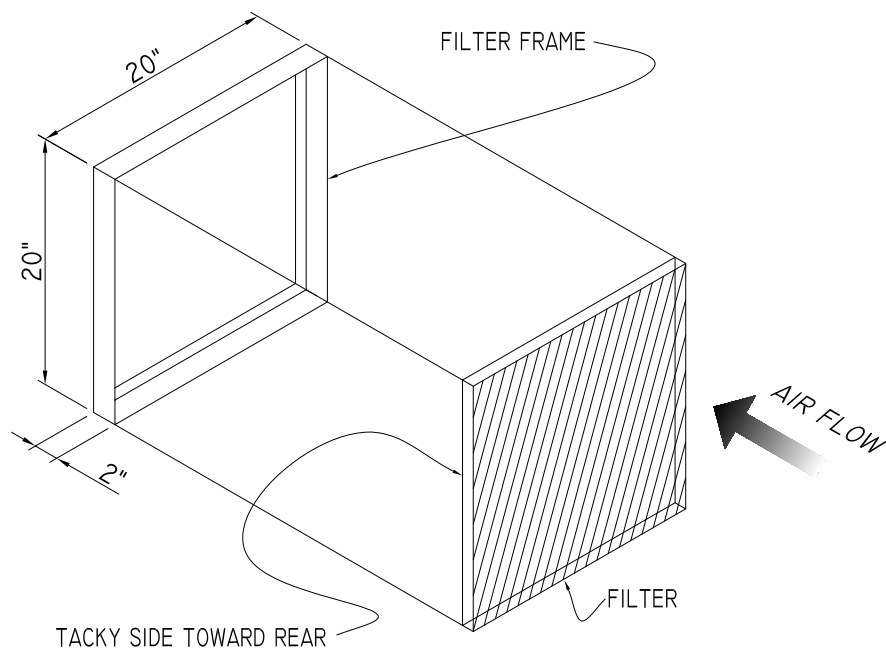

## 4.9 Motor Installation

Couplings, drive belts, chains or other mounted devices must be in proper alignment, balanced and secure for safe motor operation.

### 4.9.1 Mounting

This motor must be securely mounted. Sufficient ventilation must be provided to insure proper operation.

### 4.9.2 Install Sheaves And Fan Belts

1. The fan sheave (A) and motor sheave (B) must be in axial alignment. Shafts must be parallel in both vertical and horizontal planes.
2. The sheaves must be in radial alignment. When sheaves are of equal width, align with a straightedge (C). When sheaves are of unequal width, align center of sheaves.
3. Check fan belts for proper tension and for signs of wear. Belt (D) is properly adjusted. Belt (E) is too loose. Belt (F) is too tight.

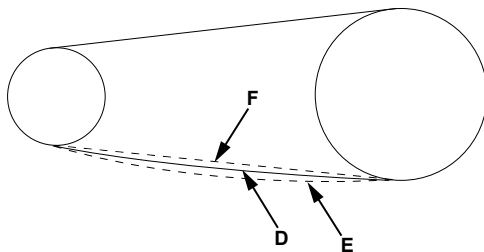
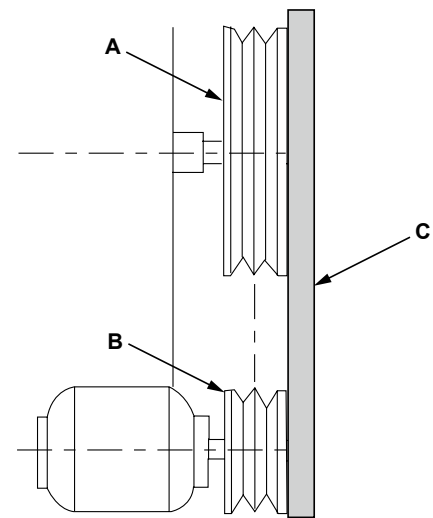

### 4.9.3 Electrical

#### **⚠ WARNING**

**Prevent serious injury or death.**

**Electrical installations must be performed by qualified electricians.**

**Installation must conform to all national, local, and provincial codes and standards.**

Complete booth assembly and then perform steps 1-5 below to connect electrical service to motor.

1. Determine voltage at your facility. RTT does not recommend using 120V single phase on motors above 1HP.
2. If a control panel or motor starter was ordered with this booth, confirm that the voltage and phase on the control panel matches the voltage and phase you intend to use.
3. Locate the wiring diagram inside the control panel that matches your voltage, phase, and HP.
4. Some motors may have 2 additional red wires. These wires are for an internal thermal overload. We do not use these wires and they should be capped off with wire nuts or electrical tape.
5. Locate the rotation arrow on the fan and verify belts are rotating in the direction of the arrow. If the belts are not rotating in the direction of the arrow, reverse the motor.
6. To insure proper wiring refer to motor nameplate for wiring diagram.

#### 4.10 Tubeaxial Fan

**⚠ WARNING**

**Fan assembly is heavy.**

**Fan assembly weight is approximately 50 - 200 lbs., depending on model. Use an adequate lifting device to install fan assembly.**

**⚠ WARNING**

**Prevent serious injury or death.**

**Electrical installations must be performed by qualified electricians.**

**Installation must conform to all national, local, and provincial codes and standards.**

The fan and motor assembly will bolt to fan panel.

#### 4.11 Exhaust Duct Installation

If equipped with optional exhaust ductwork, it is recommended to have this professionally installed.

To assemble ductwork:

1. Bolt pipe with connecting ring to the exhaust fan.
2. Remaining ductwork is crimped on one end to interlock with the next section. Crimped ends of duct shall be installed with the crimped edge pointed inward in the direction of airflow.
3. Your ARV (automatic roof ventilator) will be mounted on top.
4. Storm collar will attach to duct above flashing to make it weather proof.

Where more than 25 ft. of piping is required, static pressure (resistance) is increased and the airflow may be hindered when using the standard exhaust unit recommended for use with the booth.

Where a piping arrangement of an unusual nature is necessary or where two or more elbows are used, a similar condition may exist. Therefore, if either of these situations arises, contact RTT for recommendations.

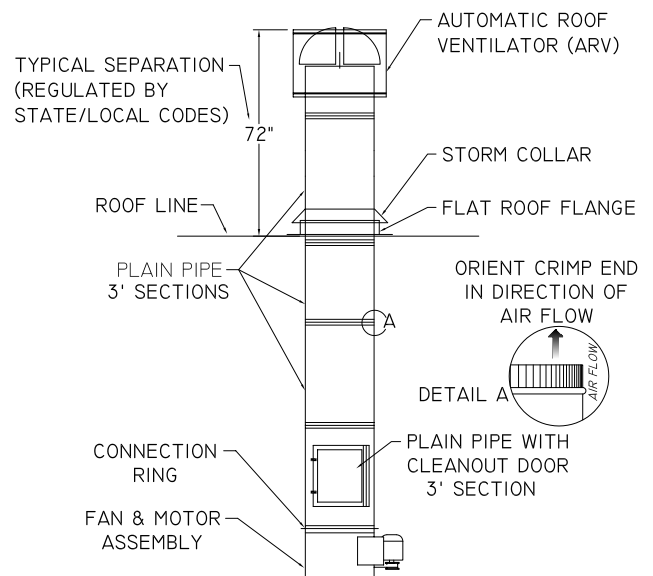

Exhaust piping, including the ARV (if used), should extend a minimum of 6 ft. above the highest point of building. There should be an access door just above exhaust unit.

#### 4.12 Product Door

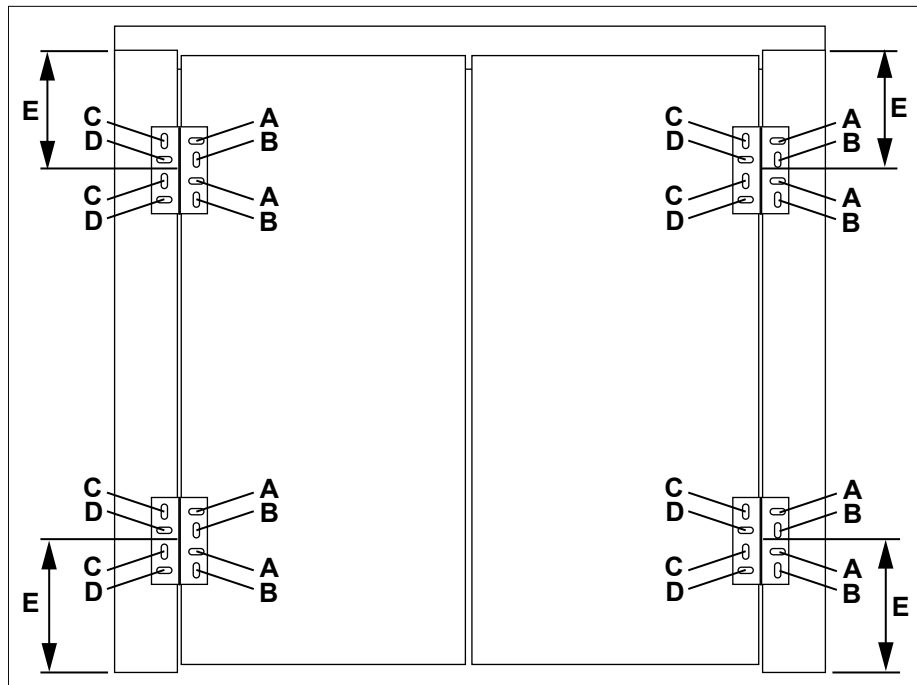

Side of door with 2 x 4 in. tube is the hinge side.

Before installing door, verify both door channels and top door stop installed properly and squared. Verify dimension between channels and floor to door stop with door drawing.

#### Install Left Door

1. Place spacers between door and floor. Door is manufactured to have a 1 in. clearance at bottom, 1/2 in. clearance on top and 1/2 in. clearance on sides.
2. Put hinges in place per dimension (E) on door drawing. Install screw in center of slots A and C on all hinges. Do not tighten screws at this time.
3. Adjust the door in all directions. Assure the door closes completely, then tighten screws.
4. Install screws in center of slots B and D.
5. Remove spacers.
6. Repeat steps 1-5 to install right door.

### 4.13 Access Door Limit Switch Installation

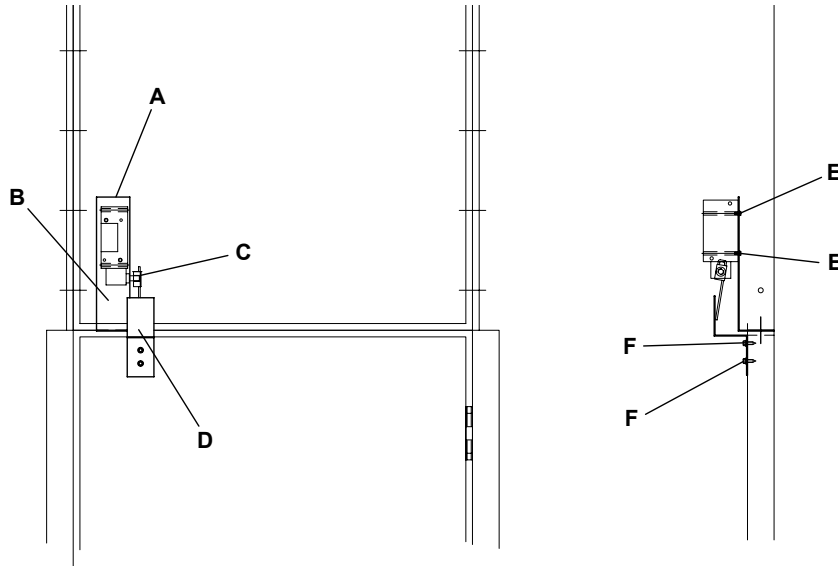

Front View

Side View

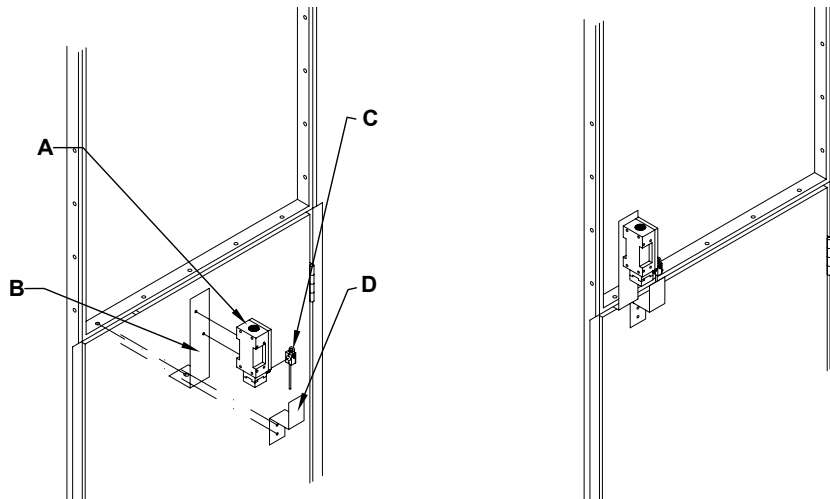

1. Bolt limit switch (A) to limit switch mounting bracket (B) with No.20 x 3/8 in. bolts (E).
2. Unbolt bolt in panel above access door on latch side and bolt the limit switch mounting bracket in place.
3. Measure and cut limit switch lever arm (C) to desired length.
4. Attach limit switch lever arm (C) to limit switch (A) (do not tighten set screw at this time).
5. Attach limit switch trigger plate (D) to door with self tapping screws (F) in front of limit switch lever arm.
6. Make final adjustments to lever arm to assure proper operation.
7. Tighten set screw on limit switch lever arm (C).

#### 4.14 Access Door Latch Installation

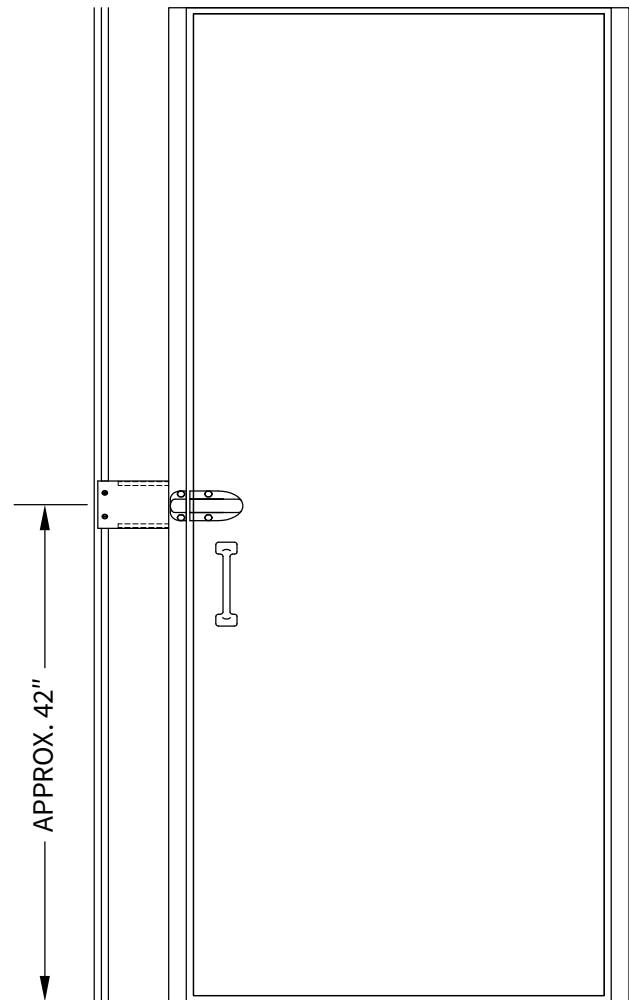
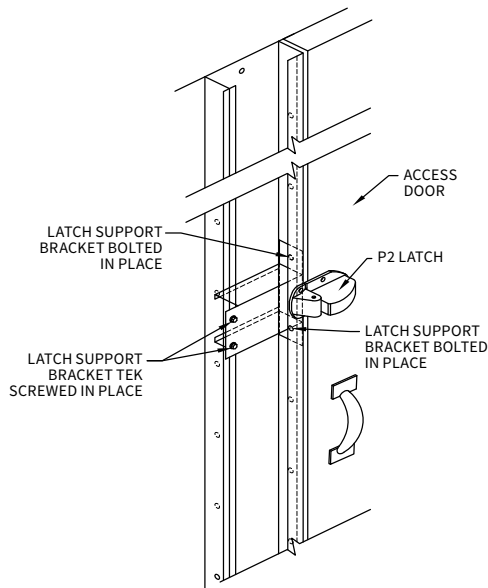
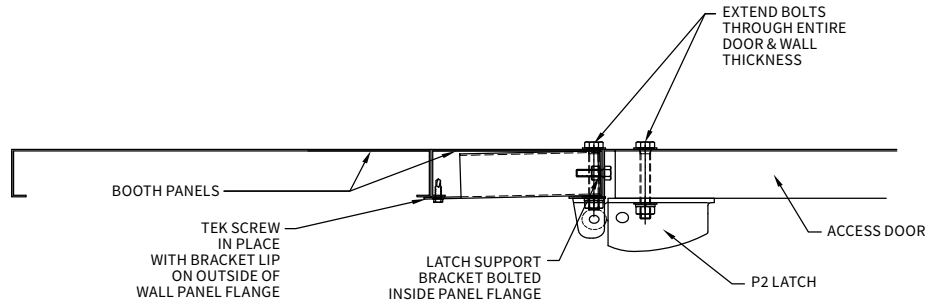

1. Unbolt two bolts that connect panel and door frame approx. 42" from the floor.
2. Insert door latch bracket into panel flange with the tail laying over the opposite panel flange.
3. Reinsert bolts and tighten.
4. Drill and bolt the P-2 latch striker plate through the door latch bracket and the wall panel.
5. Drill through the door and bolt the P-2 latch to it.
6. Tek screw the tail end of the door latch bracket to the other panel flange.

#### 4.15 Product Door Limit Switch Installation

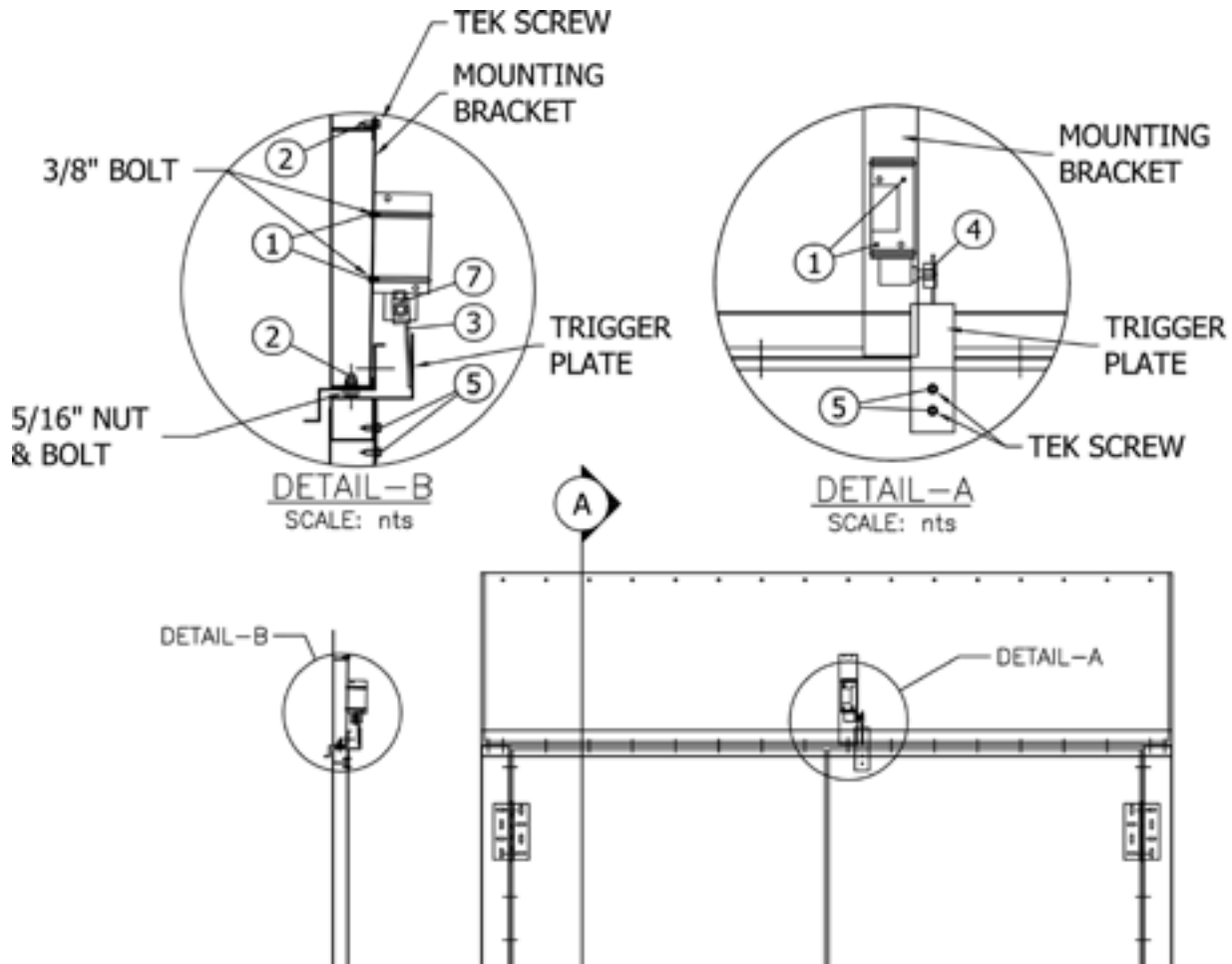

1. Bolt limit switch to limit switch mounting bracket with 3/8 in. bolts.
2. Unbolt bolt in panel and door stop above center of product door and bolt the limit switch mounting bracket in place. Tek screw the top of the bracket to the upper panel return, if present.
3. Measure and cut limit switch lever arm to desired length.
4. Attach limit switch lever arm to limit switch (do not tighten set screw at this time).
5. Attach the access door limit switch trigger plate to access door with self tapping v screws in front of limit switch lever arm.
6. Make final adjustments to lever arm to assure proper operation.
7. Tighten set screw on limit switch lever arm.

#### **4.16 Checklist**

Check the following items prior to start up:

1. Motors wired for proper voltage.
2. All fans and motors turn freely.
3. Lubricate all bearings.
4. Check installation of exhaust fan for proper airflow direction. Generally, exhaust fan airflow is out of booth.
5. Listen for excessive or unusual noise when booth is operating.
6. When door limit switches are applicable, operate the booth and open any door to see if spray gun will shut down. This will verify proper safety operation of the booth.

## 5. Maintenance

<b>⚠ WARNING</b>
<p><b>Prevent serious injury or death.</b></p> <p><b>Disconnect and lockout / tagout all power sources before adjusting, repairing, or cleaning booth.</b></p>

<b>⚠ WARNING</b>
<p><b>Prevent serious injury or death.</b></p> <p><b>Service, maintenance and adjustments must be performed by trained and qualified personnel.</b></p>

<b>⚠ WARNING</b>
<p><b>Burn hazard. Do not touch hot parts.</b></p> <p><b>Allow to cool before servicing.</b></p>

<b>⚠ WARNING</b>
<p><b>Prevent serious injury or death.</b></p> <p><b>Always wear personal protective equipment (PPE) specific to the job.</b></p> <p><b>Read Material Safety Data Sheet for products used in spray booth.</b></p>

Review and follow all safety precautions before performing any maintenance.

### 5.1 Maintenance Interval Chart

Item	Maintenance Interval			
	Daily	Every Two Months	Every Six Months	Every Year
Visually Inspect Filters	●			
Lubricate Door Latches		●		
Check And Adjust Belt Tension*			●	
Inspect And Clean Motor				●
Inspect And Clean Air Solenoid Safety Valve				●

\* Adjust belt tension after first week of operation, then every six months thereafter.

## **5.2. Daily**

### **5.2.1 Inspect Filters**

Visually inspect all filters for damage and debris buildup. Replace damaged or clogged filters.

### **5.2.2 Filter Maintenance**

<b>⚠ WARNING</b>
<b>Prevent serious injury or death.</b>
<b>Always wear personal protective equipment (PPE) specific to the job.</b>

Wear personal protective equipment to protect against dry paint and dust particles while handling filters.

Check manometer gauge daily for condition of filters. Do not change filter based on its appearance.

Filters are not necessarily changed at equal time intervals. The usable life of a filter is related to:

- Filter material weave
- Paint sprayed
- Distance from gun to filter
- Paint gun type
- Amount of thinner used
- Spray pressure

### **5.2.3 Determine Filter Condition**

1. The filter condition is acceptable when the manometer tube scale is between the two arrows.
2. When manometer scale exceeds red pointer flag, filters must be changed.
3. If a different filter media is to be used, manometer setup procedure may need to be changed based on the capacity rating of the media.

## **5.3 Every Two Months**

### **5.3.1 Lubricate Door Latches**

Lubricate bearing pin and laminated cam with SAE 30-50 high temperature oil. Tighten set screws in handle as needed.

For use in cold areas, use SAE 10-20 high temperature oil.

Test explosion-venting feature to verify proper operation. Corrosion and/or build-up of foreign materials may affect proper operation of latches.

## 5.4 Every Six Months

### 5.4.1 Check Fan Belts

1. The fan sheave (A) and motor sheave (B) must be in axial alignment. Shafts must be parallel in both vertical and horizontal planes.
2. The sheaves must be in radial alignment. When sheaves are of equal width, align with a straightedge (C). When sheaves are of unequal width, align center of sheaves.
3. Check fan belts for proper tension and for signs of wear. Belt (D) is properly adjusted. Belt (E) is too loose. Belt (F) is too tight.

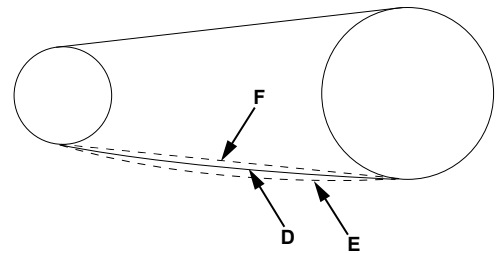
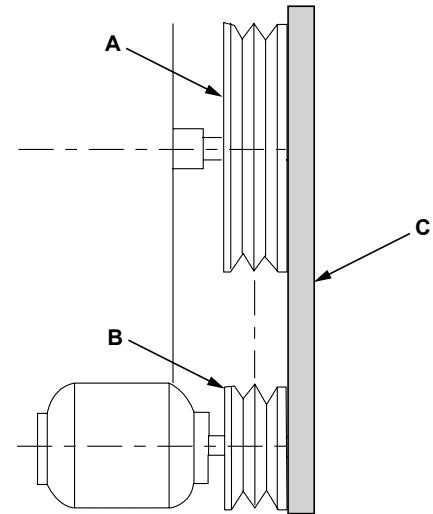

## 5.5 Every Year

### 5.5.1 Inspect Motor

Verify that cooling air to motor has not been diverted or blocked by dirty guards or other obstacles.

### 5.5.2 Inspect Fan Wheel

Inspect fan wheel for buildup of material, which may cause an unbalanced fan wheel. An unbalanced fan wheel may lead to premature failure of the fan wheel, bearings and belt. Clean material buildup as necessary.

### 5.5.3 Inspect And Clean Air Solenoid Valve

The function of this valve is to interrupt the supply of compressed air to the painting equipment when the booth is not operating as designed or if any booth doors are open.

**⚠ WARNING**

**Prevent serious injury.**

**Turn off electrical power, depressurize valve, and vent fluid to a safe area before servicing valve.**

The time between cleanings varies depending on the medium and service conditions. If voltage to coil is correct, sluggish valve operation, excessive noise or leakage indicates that cleaning is required. Clean strainer or filter when cleaning valve. Thoroughly clean all parts. If parts are worn or damaged, install a complete rebuild kit.

Follow instructions included with air solenoid valve.

## 6. Warranty

RTT Engineered Solutions has a full one year warranty that begins from the day of shipment on all parts and materials. This warranty does not extend to include labor costs for the replacement of parts or materials covered under warranty.

If a part is believed defective, please notify our Customer Service Department. A replacement item shall be shipped and regular freight shall be paid by RTT.

If RTT requires the defective part to be returned, appropriate return freight costs shall be paid by RTT.

**IMPORTANT:** Before returning the defective part(s), you must first get an RGA (Return of Goods Authorization) from our Customer Service Department. A copy of the RGA document **MUST** be included with the returned item(s).

The Seller warrants to Buyer that the equipment mentioned herein shall be free from defects of materials or workmanship under normal use and maintenance for a period of one (1) year from date of shipment. The liability of Seller under this warranty shall be limited to the repair or replacement, at Seller's option, of any part or component which may prove to be defective under normal use, service and maintenance after Seller, in its sole discretion, determines same to be defective. Said warranty is conditioned upon Buyer giving Seller immediate written notice of an alleged defect and refraining from the attempted repair of alleged defects without prior written consent of Seller. The Seller makes no warranty whatsoever with respect to accessories or components not supplied by Seller. For any components purchased by Seller for use on or in conjunction with the equipment which is the subject of this contract, the Seller extends to the Buyer only the same warranty granted to Seller by the component vendor or manufacturer.

THIS LIMITED WARRANTY IS EXCLUSIVE AND IS IN LIEU OF ANY OTHER WARRANTIES (EXPRESS OR IMPLIED) INCLUDING WARRANTY OF MERCHANTABILITY OR WARRANTY OF FITNESS FOR PARTICULAR PURPOSE AND OF ANY NON-CONTRACTUAL LIABILITIES INCLUDING PRODUCT LIABILITIES BASED ON NEGLIGENCE OR STRICT LIABILITY. EVERY FORM OF LIABILITY FOR DIRECT, SPECIAL, OR CONSEQUENTIAL DAMAGES OR LOSS IS EXPRESSLY EXCLUDED AND DENIED. IN NO CASE SHALL RTT ENGINEERED SOLUTIONS LIABILITY ON THIS WARRANTY EXCEED THE AMOUNT OF THE PURCHASE PRICE.

The performance and safety of the equipment mentioned herein is contingent upon proper installation, the use of suitable process materials and operation and maintenance by properly trained personnel.

During the warranty period, RTT will repair or replace, free of charge, any parts that RTT Engineered Solutions has verified to be defective in materials or workmanship. If inspection of the equipment does not disclose any defect in workmanship of material, repairs will be made at a reasonable charge, which will include the costs of labor, materials and transportation.

### **6.1 Returning Items For Credit**

RTT Engineered Solutions will take back any standard stocked items returned and issue a credit, less a 20% handling and restocking fee. Customer is responsible for all freight charges and the item

MUST be returned in its original condition. If the item is damaged in transit you will not receive credit. RTT will mark the Bill of Lading "Damaged" and send you pictures of the damaged item. For custom or non-stock special order items you must contact our Customer Service Department to determine if the item may be returned. Any restocking charges shall be determined on a case by case basis.

If an item needs to be returned, RTT will issue you an RGA (Return Goods Authorization) form. Please ensure that a copy is sent back with returned item(s). Without an RGA the product may be lost or returned to stock with no credit issued. Please note that in some cases the freight may be more than the item is worth when credit is received.

## **6.2 Back Charges For Material And Labor**

RTT Engineered Solutions shall not be held responsible for any back charges incurred for materials or labor without prior written consent.

Should a problem arise, please notify RTT immediately. Once the issue is investigated, should costs be incurred, an amount shall be agreed on by both parties beforehand. Do NOT attempt modifications or repairs without prior consent as this may void further warranty repairs or credit. RTT will not accept back charges associated with late delivery.

Please address repairs to:

RTT Engineered Solutions  
2975 Discovery Blvd.  
Rockwall, TX 75032  
Attention: Customer Service  
Phone: 888-452-6684  
Email: [sales@rttsolutions.com](mailto:sales@rttsolutions.com)

**888-452-6684**  
**[www.rttolutions.com](http://www.rttolutions.com)**